

Structural attachments, trapezes, clamps, slide plates

7

STRUCTURAL ATTACHMENTS,
TRAPEZES, CLAMPS, SLIDE PLATES

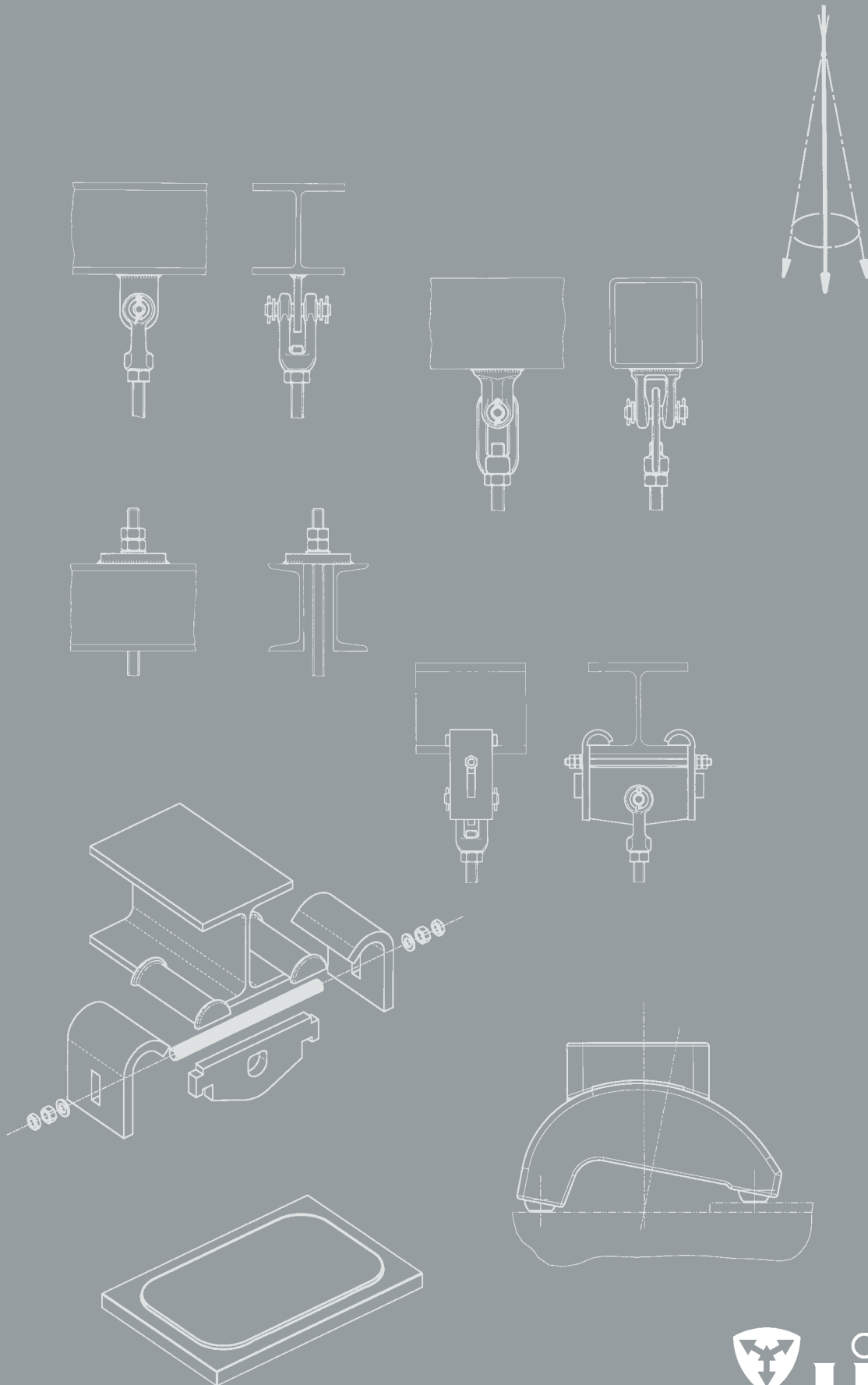

PRODUCT
GROUP

7

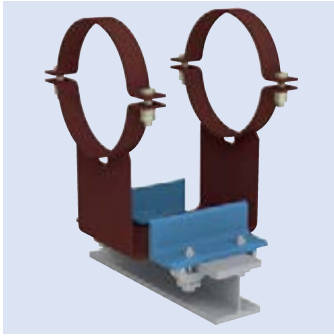
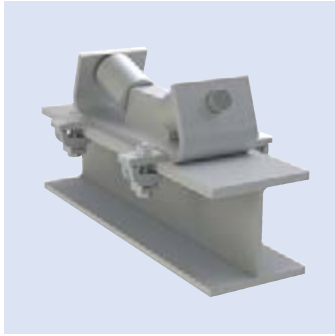
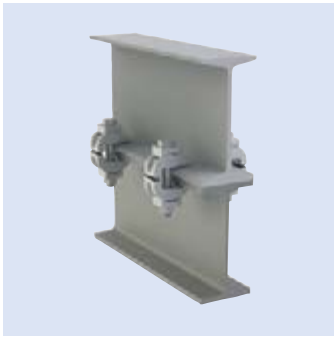

Structural attachments, trapezes, clamps, slide plates

Contents	Page
Structural attachments, trapezes	7.1
Weld-on clevises type 73	7.2
Weld-on eye plates type 75	7.2
Weld-on plates with spherical washers type 74	7.3
Clamps and trapezes	7.4
Beam clamps type 78	7.4
Trapezes type 79	7.4
Beam adapters type 76	7.6
Guides with beam adapters type 76 for clamp bases type 49	7.8
Cantilevers with beam adapters type 76	7.8
Slide plates	7.10
Instructions on assembly and installation	7.12
Slide plates to weld-on type 70	7.13
Slide plates for bolting type 70	7.15

0

1

2

3

4

5

6

**PRODUCT
GROUP 7**

8

9

Structural attachments, trapezes, clamps, slide plates

Special components for welding or clamping are available for connecting the pipe supports to the supporting structure. In order to fulfill safety requirements the connections must be suitable.

Product group 7

Connecting components for the direct attachment to the structure and trapezes form part of product group 7.

The permissible loads for the components correspond to the load table for statically determined components in the 'technical specifications', p. 0.6.

For weld-on clevises type 73 – well suited for connection to hollow sections - and weld-on eye nuts type 75 the specified minimum weld seam thicknesses must be taken into account. These are calculated not to exceed a maximum weld seam stress of 75N/mm^2 (load case H). For the calculations, a force applied conically below 6° was served as the basis.

The weld-on plates type 74 enable use of the maximum pendulum length in restricted spaces by means of a plug connection. Here too, a force applied conically below 6° served as the basis.

Beam clamps type 78 are designed for **weld-free** connection on site. They are suitable for all beam widths and flange slopes. When ordering, please state beam widths and flange thicknesses.

For protection against corrosion the components are given a weldable primer coating ($30\mu\text{m}$) or are galvanized (layer thickness $12\text{-}15\mu\text{m}$).

Trapezes type 79 are for the attachment of clamp bases type 49 and type 56 and can be used for rigid suspension as well as for connection with spring and constant hangers.

The trapeze profiles are protected against corrosion according to LISEGA standard color coating (see p. 0.10).

All components can on request be supplied with material certifications.

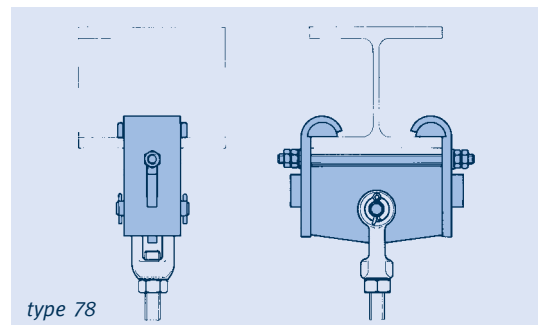
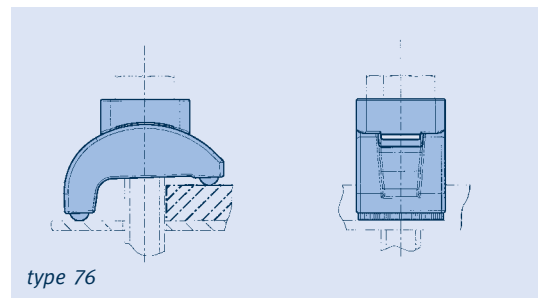
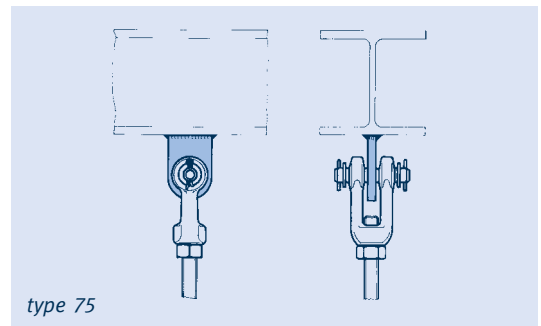
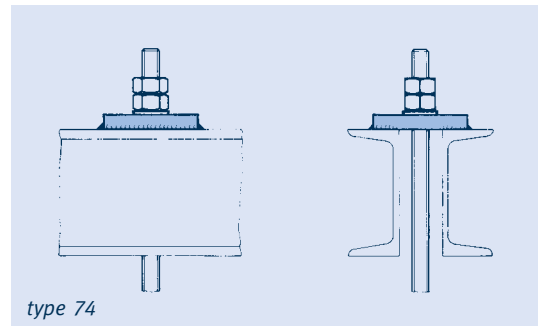
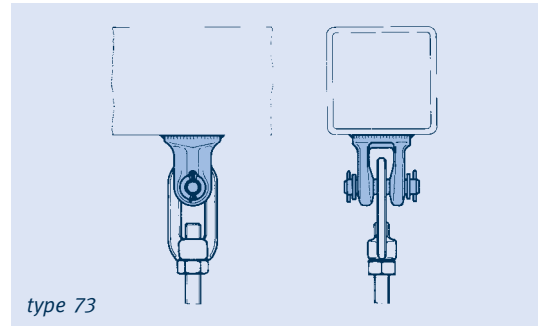

Standardized connection possibilities

Weld-on clevises Type 73 Weld-on eye plates Type 75

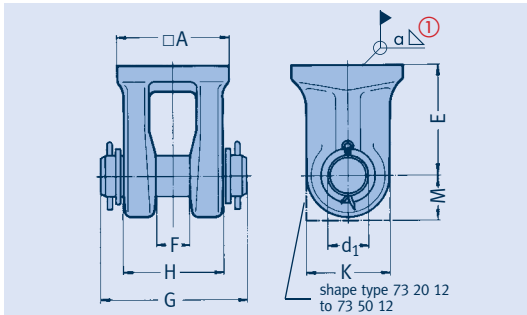

Weld-on clevises type 73 29 13 to 73 50 12

Material: S355J2
drop-forged.

From load size 20 onwards:
flame-cut design made
of S355J2
bolts: C35E+QT.

type	□A	∅d ₁	E	F	G	H	K	M	min. weld seam ①	weight [kg]
73 29 13	40	12	35	12	60	34	24	–	3.0	0.3
73 39 13	50	16	40	17	70	44	32	–	3.0	0.4
73 49 13	65	20	50	20	90	57	46	–	3.0	1.1
73 59 13	75	24	60	22	105	68	53	–	3.0	2.1
73 69 12	95	33	90	27	125	80	64	–	3.5	3.8
73 79 12	120	40	110	32	140	93	80	–	4.0	6.8
73 89 12	120	45	120	37	165	110	90	–	5.5	9.2
73 99 12	120	50	130	42	185	120	100	–	7.5	11.1
73 10 12	150	60	140	50	210	150	120	–	8.5	18.5
73 20 12	170x175	70	150	60	245	165	170	75	9.0	37.0
73 30 12	170x175	70	150	60	245	165	170	75	10.5	37.0
73 40 12	150x190	80	170	56	230	150	150	90	12.5	38.0
73 50 12	180x220	90	195	64	240	165	180	110	13.5	58.0

① Calculation of the weld seams was based on a permissible stress of 75N/mm² in load case H.

Order details:
weld-on clevises 73 .. 1.

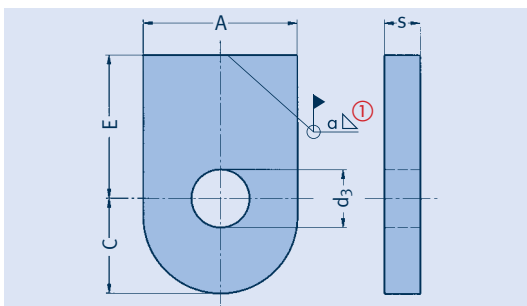

Weld-on eye plates type 75 D1 19 to 75 50 12

Material: S235JR
from load group 6: S355J2.

type	A	∅d ₃	E	C	s	min. weld seam ①	weight [kg]
75 D1 19	30	10.5	40	18	6	3.0	0.10
75 21 12	35	12.5	45	22	8	4.0	0.13
75 31 12	45	16.5	50	28	10	4.5	0.24
75 41 12	60	20.5	55	37	12	6.0	0.45
75 51 12	65	24.5	60	40	15	7.0	0.65
75 61 12	80	34	70	50	20	8.5	1.25
75 71 12	100	41	80	65	25	9.5	2.35
75 81 12	120	46	90	75	30	10.5	3.9
75 91 12	130	51	100	80	30	13.5	4.6
75 10 12	150	61	110	90	40	15.5	7.7
75 20 12	170	71	120	100	45	18.0	10.6
75 30 12	180	71	130	110	45	20.5	12.6
75 40 12	220	81	140	120	50	18.5	18.5
75 50 12	250	91	150	135	60	20.0	27.5

① Calculation of the weld seams was based on a permissible stress of 75 N/mm² in load case H.

Order details:
weld-on eye plates
type 75 .. 1.

Weld-on plates with spherical washers Type 74

Weld-on plates with spherical washers type 74 D1 19 to 74 50 13

Material spherical washers:
case-hardened steel.

From load group 5: C15
weld-on plate: S235JR.

For $s \geq 20$: S355J2.

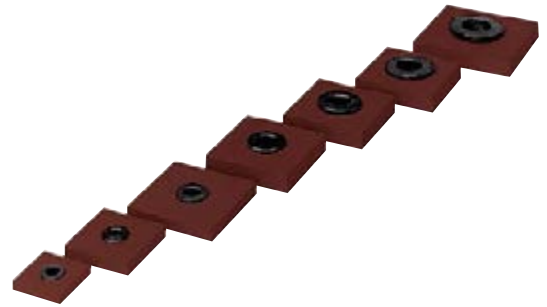
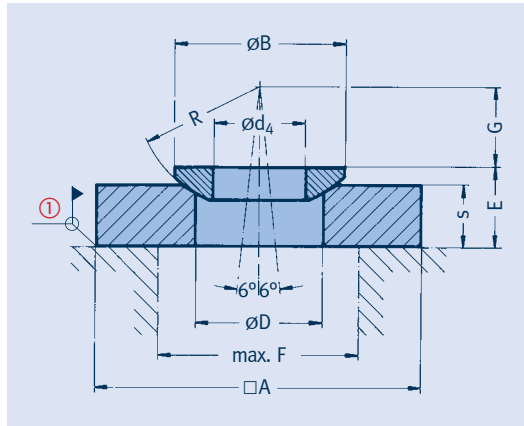

① LISEGA recommends tack
welding of the weld-on plate
for fixing positions or welding
all round as specified.

type	for thread	$\square A$	$\varnothing B$	$\varnothing D$	$\varnothing d_4$	E	max. F	G	R	s	weight [kg]
74 D1 19	M10	60	21	15	10.5	12	35	10	15	10	0.3
74 21 13	M12	70	24	18	13	17	40	11	17	15	0.6
74 31 13	M16	70	30	25	17	17	45	15	22	15	0.6
74 32 13	M16	95	30	25	17	22	45	15	22	20	1.4
74 33 13	M16	130	30	25	17	22	45	15	22	20	2.7
74 41 13	M20	70	36	30	21	18	50	18	27	15	0.6
74 42 13	M20	95	36	30	21	23	50	18	27	20	1.4
74 43 13	M20	130	36	30	21	23	50	18	27	20	2.7
74 51 13	M24	95	44	35	25	24	55	21	32	20	1.4
74 52 13	M24	130	44	35	25	24	55	21	32	20	2.7
74 61 13	M30	130	56	45	31	35	60	27	41	30	4.0
74 62 13	M30	170	56	45	31	35	60	27	41	30	6.8
74 71 13	M36	130	68	50	37	37	70	32	50	30	4.0
74 72 13	M36	170	68	50	37	37	70	32	50	30	6.8
74 81 13	M42	130	78	59	43	39	90	37	58	30	4.0
74 82 13	M42	170	78	59	43	39	90	37	58	30	6.8
74 91 13	M48	130	92	66	50	46	120	41	67	35	4.5
74 92 13	M48	170	92	66	50	41	120	41	67	30	6.8
74 10 13	M56x4	225	103	76	58	47	140	50	79	35	13.9
74 20 13	M64x4	250	120	89	66	54	150	59	93	40	19.6
74 30 13	M68x4	250	128	95	70	61	160	64	100	45	22.0
74 40 13	M72x4	300	136	98	75	61	160	70	107	45	31.8
74 50 13	M80x4	350	152	110	83	64	180	78	120	45	43.3

Order details:

weld-on plate with spherical
washer type 74 .. 1.

Beam clamps Type 78 Trapezes Type 79

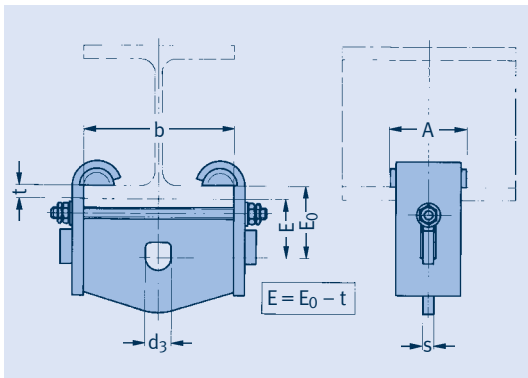

Beam clamps
type 78 21 11 to 78 71 11

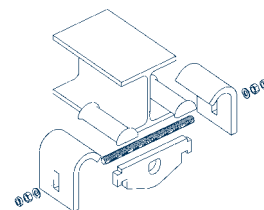

type	d ₃	A	E ₀ up to beam width b=										s	t _{max} ②	weight [kg]
			46	82	100	125	140	180	220	260	300				
78 21 11	17	80	55	55	65	65	65	75	85	-	-	8	15	0.8 – 1.6	
78 31 11	21	80	-	70	70	70	70	80	90	100	110	10	20	2.0 – 3.6	
78 41 11	25	125	-	-	-	85	90	90	100	105	115	15	25	6.7 – 8.9	
78 51 11	34	125	-	-	-	95	95	105	115	130	140	15	25	6.8 – 9.5	
78 61 11	41	180	-	-	-	-	-	100	100	110	110	20	30	17.7 – 19.8	
78 71 11 ①	51	180	-	-	-	-	-	115	115	125	130	20	30	18.2 – 20.8	

- ① Load sizes 8 + 9 can also be connected. The permissible load amounts to 100kN in load case H.
- ② Larger 't' dimension possible on request – E₀ increases correspondingly. When ordering please state beam width 'b' and flange thickness 't'.

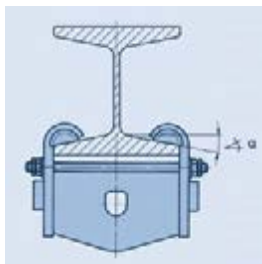
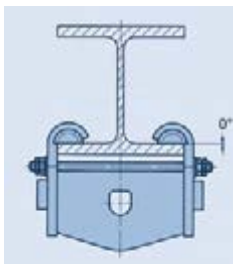

Order details:
beam clamp
type 78 .1 11
beam width b = ...mm
flange thickness t = ...mm

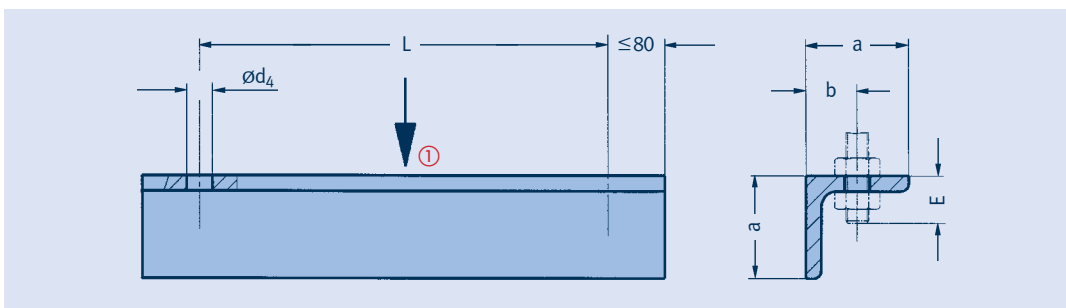

Trapezes for the use
of lower loads at
temperatures ≤ 80°C
type 79 C2 37 to 79 42 37

- ① The permissible center load is to be taken from the respective trapeze load group (3rd digit in the type designation).

type	L _{max}	E	a	b	ød ₄	weight [kg] for L=500mm ± per 100mm	
						weight [kg]	weight [kg]
79 C2 37	1000	25	40	22	11	1.7	0.3
79 D2 37	1000	25	60	25	11	2.6	0.46
79 12 37	600	25	60	25	11	2.6	0.46
79 12 37	1000	25	70	28	11	3.8	0.64
79 22 37	600	30	70	28	14	3.8	0.64
79 22 37	1100	30	80	32	14	6.0	1.0
79 32 37	600	30	80	32	14	6.0	1.0
79 32 37	1200	30	100	35	14	9.6	1.5
79 42 37	600	40	100	38	18	9.6	1.5
79 42 37	1200	40	130	42	18	15.6	2.4

Order details:
trapeze
type 79 .2 37, L = ...mm

Trapezes Type 79

Trapezes type 79 22 34 to 79 20 34

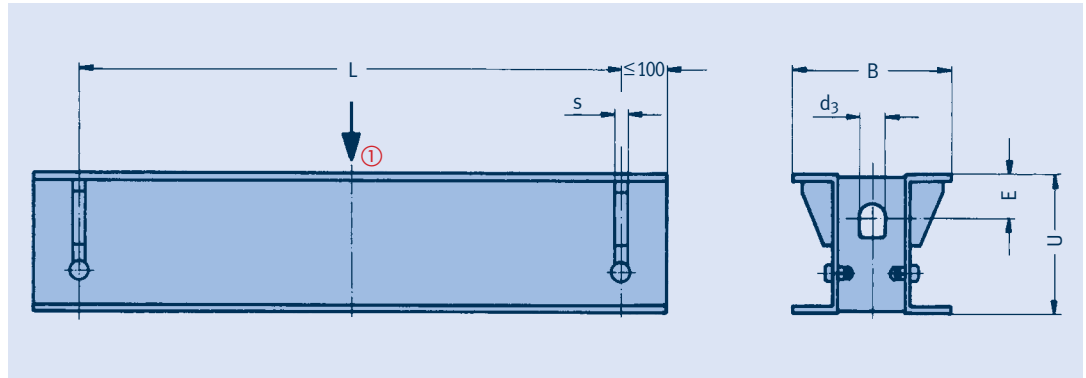

① The permissible center load is to be taken from the respective trapeze load group (3rd digit or 3rd and 4th digits in the type designation).

② The L_{max} dimensions can be lengthened up to 2400mm on load reduction of 5% per 100mm extension.

③ Connection possible for the specified load groups.

type	load ③ group	$d_3 \geq$	$s \leq$	L_{max} ②	E	U	B	weight [kg] for L = 1000mm \pm per 100mm	
79 22 34	D - 4	21	10	1700	20	80	140	19	1.7
79 32 34	D - 4	21	10	1700	20	80	140	19	1.7
79 42 34	3 - 4	21	12	900 1800	20 40	80 120	140 190	19 31	1.7 2.7
79 52 34	4 - 5	25	18	1400 1800	40 40	120 140	190 200	31 38	2.7 3.2
79 62 34	5 - 6	34	20	1250 1800	40 55	140 180	200 230	38 54	3.2 4.4
79 72 34	6 - 7	41	25	1400 1800	60 65	180 200	230 250	54 65	4.4 5.1
79 82 34	6 - 8	46	25	1250 2400	70 80	200 260	250 310	65 102	5.1 7.6
79 92 34	7 - 9	51	30	1800 2400	85 90	260 300	310 350	102 129	7.6 9.2
79 10 34	8 - 10	61	30	2000	95	300	350	129	9.2
79 20 34	9 - 10	61	30	1800	95	300	350	129	9.2

Order details:

trapeze
type 79 .. 34, L = ...mm

Trapeze type 79 23 39 to 79 93 39

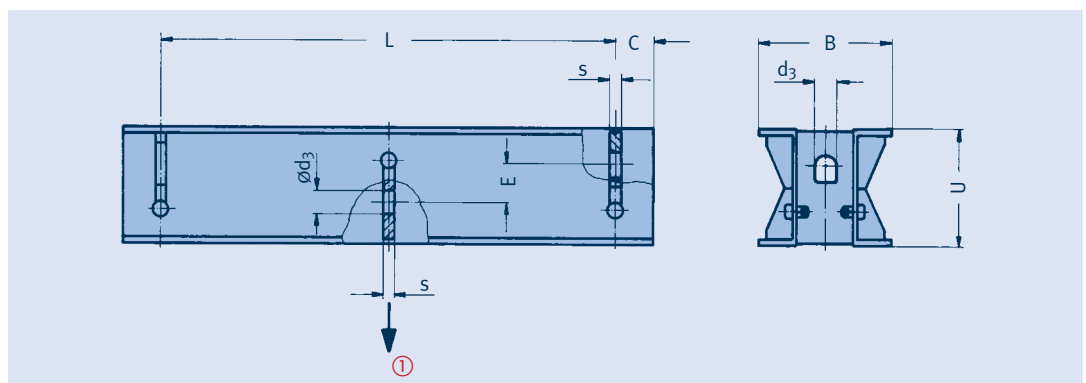

① The permissible load for the middle connection is to be taken from the respective trapeze load group (3rd digit in the type designation).

② L_{max} can be lengthened to 2400mm for type 79 23 39 to 79 73 39 on reduction of the permissible load by 5% for every 100mm.

③ Connection possible for the specified load groups.

type	load ③ group	d_3	L_{max} ②	E	U	B	C	s	weight [kg] for L= 1000mm \pm per 100mm	
79 23 39	D - 4	21	1700	40	80	140	40	10	19	1.7
79 33 39	D - 4	21	1700	40	80	140	40	10	19	1.7
79 43 39	3 - 5	25	1800	40	120	190	50	12	32	2.7
79 53 39	4 - 6	34	1800	60	140	200	60	18	40	3.2
79 63 39	5 - 7	41	1800	65	180	230	70	20	56	4.4
79 73 39	6 - 8	46	1800	65	200	250	80	25	68	5.1
79 83 39	6 - 9	51	2400	95	260	310	90	25	108	7.6
79 93 39	7 - 10	61	2400	120	300	350	100	30	138	9.2

Order details:

trapeze
type 79 .3 39, L = ...mm

Beam adapters Type 76

On alterations or extensions of the pipe systems or steelwork in existing plants, clamp connections are frequently preferred to welded connections. Clamp connections are strictly specified in cases where welding connections are excluded for safety reasons.

The safety of the clamping effect of such connections depends essentially on the nature of the existing contact surfaces and the prestressing forces applied. The design of the clamping components used is therefore decisive for a reliable connection.

For the creation of safe and reliable clamp connections LISEGA offers the beam adapter system type 76. These components enable the connection of very different components to existing steelwork without welding or drilling.

Assembly is simple and timesaving. On tightening, LISEGA beam adapters adjust independently to the existing beam thickness.



If the specified tightening torques are observed, lasting security of the connections is guaranteed. Any corrosion protection already present, such as hot-dip galvanization or paint coatings, incurs no damage.

The special support segments are the main feature of the LISEGA beam adapters. Due to their shape they automatically adapt to any position and to existing profile angles.

**Beam adapters
type 76 D2 11 to 76 42 11**
Material: cast iron hot dip galvanized.

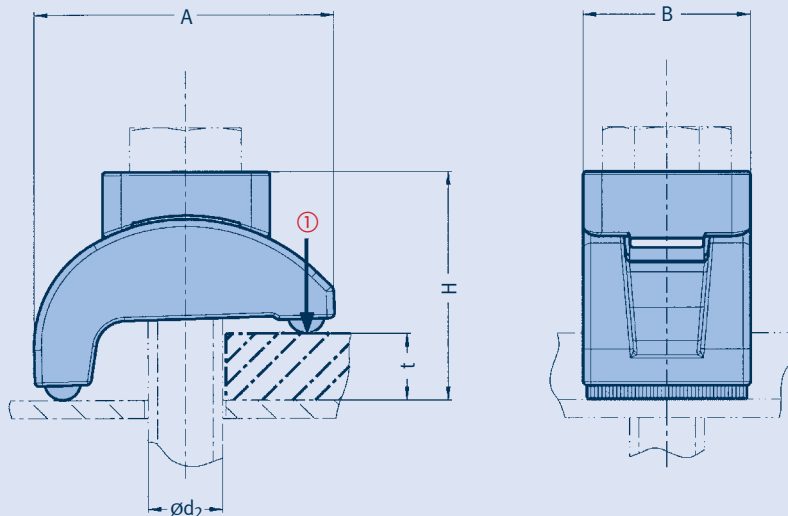
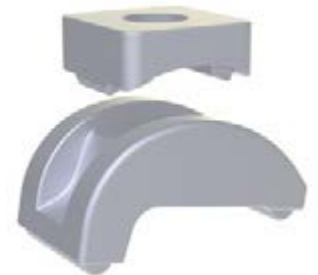

① The loads specified correspond to this in load case H. 'Max. permissible loads' p. 0.6. For further load cases see table.

② Friction value $\mu = 0.14$.

type	on bolting 8.8		A	B	$\varnothing d_2$	H_{min}	H_{max}	t		weight [kg]
	support force [kN] ①	tight. torque [Nm] max ②						(clamp thickness) min	max	
76 D2 11	2.5	35	48	24	M10	31	37	3	15	0.1
76 22 11	6.0	70	57	30	M12	37	45	4	17	0.2
76 32 11	8.5	150	70	37	M16	44	54	6	20	0.3
76 42 11	15.0	300	83	46	M20	55	65	6	25	0.6

Order details:
beam adapter (without bolt)
type 76 .. 11
bolts for beam adapters,
see p. 7.7.

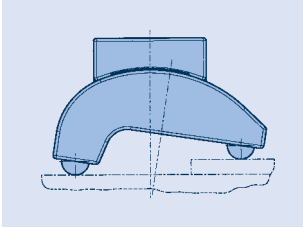

The hardened support segments have a circular groove profile that is pressed into the contact surface on tightening. This way, a **form-fit contact is produced which ensures that no shifting in any direction takes place.**

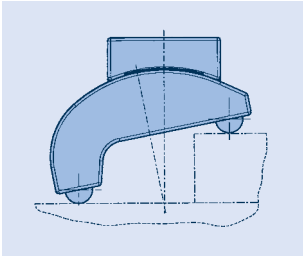
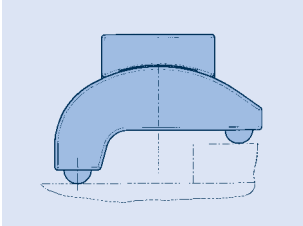

Typical utilization of beam clamps at different material thicknesses



Example of use:
Attachment of clamp base to steel beam

Example of connections with beam adapters

Cross-connection



The safe connection of beam profiles to each other is produced very easily with an inlay plate and 8 LISEGA beam adapters. The load-bearing capacity of a cross-connection can be found in the table below.

Load-bearing capacity of cross-connections with LISEGA beam adapters

type	load capacity [kN] for 4 bolts (8.8)	thickness of inlay plate
76 D2 11	10	10
76 22 11	24	12
76 32 11	34	15
76 42 11	60	18

Bolts for beam adapters

bolt type	dimensions	weight [kg]
76 D2 11 - 065	M10 x 65	0.06
76 D2 11 - 080	M10 x 80	0.07
76 D2 11 - 100	M10 x 100	0.08
76 22 11 - 070	M12 x 70	0.09
76 22 11 - 090	M12 x 90	0.10
76 22 11 - 120	M12 x 120	0.12
76 32 11 - 090	M16 x 90	0.19
76 32 11 - 120	M16 x 120	0.23
76 32 11 - 150	M16 x 150	0.27
76 42 11 - 120	M20 x 120	0.39
76 42 11 - 150	M20 x 150	0.45
76 42 11 - 180	M20 x 180	0.51

Hexagon bolts DIN EN ISO 4017, thread to head, grade 8.8, hot dip galvanized, including a hexagon nut DIN EN ISO 4032, grade 8, hot dip galvanized.



Order details:

bolt for beam adapter type 76 .2 11- ...

Profile connection



The connection of profiles to each other can be made either directly or by using an inlay plate.

Guides with beam adapters Type 76 for clamp bases Type 49 Cantilevers with beam adapters Type 76 .. 16

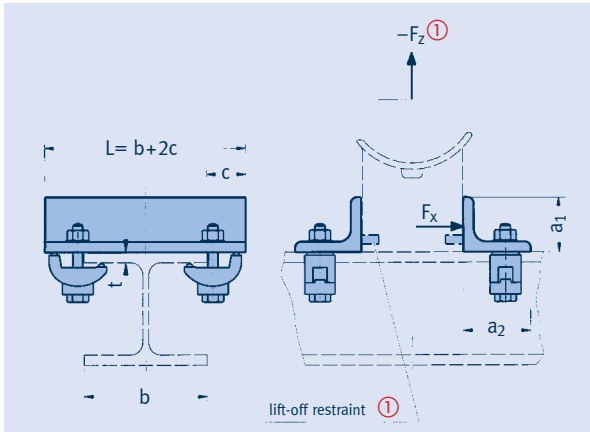

**Guide with beam adapters
for clamp bases
type 76 00 11 to 76 00 14**
Material:
guide S235JR.

type	type ① with lift-off restraint	tightening torque [Nm]	F_x [kN]	$-F_z$ ① [kN]	a_1	a_2	b_{min}	c	t_{max}	total weight [kg] for b=100 +per 100mm	
76 00 11	76 00 21	35	1.0	3.5	30	50	42	40	15	1.7	0.60
76 00 12	76 00 22	70	1.7	4.5	30	60	50	45	17	2.8	0.95
76 00 13	76 00 23	150	2.8	6.5	40	80	64	55	20	4.9	1.40
76 00 14	76 00 24	300	4.7	6.5	40	80	73	65	25	7.2	1.40

Order details:
lateral guide
type 76 00 1.; b = ...mm

Order details:
lateral guide with lift-off
restraint
type 76 00 2. - 49
(clamp base type), b = ...mm

① If required, the guides can be supplied with an additional lift-off restraint (width 80mm).
(When ordering also specify clamp base type.)
 F_z : the permissible short-duration lift-off load is limited in every case by the permissible lift-off load of the clamp base. See p. 4.68 for this.

② Friction value $\mu = 0.14$

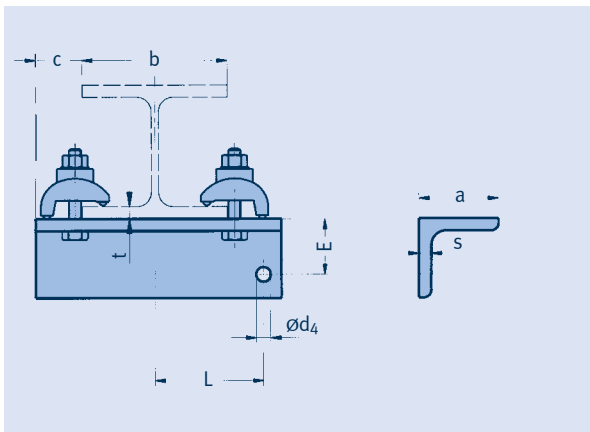

**Cantilever with
beam adapters
type 76 C1 16 to 76 21 16**
Material:
cantilever S235JR.

$$L_{min} = 0 \text{ mm} \quad L_{max} = \frac{b}{2} + c$$

type	tightening torque [Nm]	a x s	b_{min}	b_{max}	c	d_4	E	t_{max}	weight [kg] for b=100 L=50 +per 100mm	
76 C1 16	35	40x6	42	300	40	11	25	15	0.9	0.35
76 D1 16	70	60x6	50	300	45	11	45	17	1.5	0.55
76 11 16	150	70x7	55	300	55	14	48	20	2.5	0.75
76 21 16	300	80x8	64	300	65	17	55	25	3.9	1.00

① Friction value $\mu = 0.14$

Order details:
cantilever with beam
adapters type 76 .1 16
b = ...mm, L = ...mm

Cantilevers with beam adapters Type 76 .. 17

Cantilevers with beam adapters types 76 C1 17 to 76 21 17

Material:
cantilever S235JR.

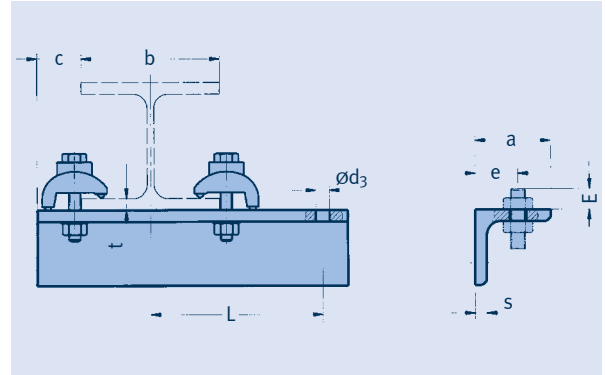

$$L \geq \frac{b}{2} + c$$

① Friction value $\mu = 0.14$

Order details:
cantilever with beam adapters type 76 .1 17
 $b = \dots\text{mm}$, $L = \dots\text{mm}$

type	max. tightening torque [Nm]	a x s	b _{min}	c	ød ₃	e	E	t _{max}	L _{max} up to beam width b=								weight [kg] for b = 100	
									82	100	125	140	180	220	260	300	+per L=100	100mm
76 C1 17	35	40x6	46	40	11	22	20	15	120	230	270	310	320	340	360	380	1.0	0.35
76 D1 17	70	60x6	55	45	11	25	20	17	105	170	200	250	280	340	360	380	1.8	0.55
76 11 17	150	70x7	64	55	14	28	25	20	110	140	170	200	230	290	350	380	2.8	0.75
76 21 17	300	80x8	73	65	14	30	25	25	145	160	190	235	265	290	310	330	4.4	1.00



Example of use:
roller bearing fitted at works
with lateral support plates



Example of use:
clamp base on trapeze

Slide plates

Type 70

Application and field of use

The pipe systems resting on pipe bearings are subject to displacement as a result of thermal expansion. This displacement must be permitted to prevent unacceptable stresses that could damage the piping system. Furthermore, the slight friction caused by these movements is reduced by inserting slide plates between the clamp base and supporting framework.

During the planning phase the reduction of friction forces is extremely important. Since friction forces can represent considerable additional forces to the operational loads, they are usually distributed into the supporting framework (building structure or secondary steelwork) by the use of low friction materials/surfaces.

By lowering friction forces the dimensioning of building structures and secondary steelwork can be, under the aspect of cost saving, reduced. Also the reaction forces in the pipe statics.

Slide plates are commonly used in all pipe systems in industrial processes / chemical plants, in the power station field, in liquefied gas transport or in district heating pipe systems.

Through the use of slide plates friction forces can be reduced about 60%. Instead of steel / steel sliding contact with a friction coefficient of $\mu \approx 0.3$, through the use of slide plates and a stainless steel plate as a counterface on the clamp base side the friction coefficient can be reduced to as little as $\mu \approx 0.1$ (dry).

LISEGA slide plates consist of different low-friction materials for different temperature ranges. For use at a constant temperature up to 180°C (at the bottom of the clamp base) the standard PTFE slide plate is recommended. For temperatures above 180°C to a maximum of 350°C a special high-temperature material is used.

Advantages of the low-friction materials

- high mechanical wear resistance
- temperature resistance up to 350°C
- suitable for use in aggressive environmental conditions due to their high chemical resistance
- self-lubricating
- permanent freedom from maintenance
- long lifespan
- excellent load-bearing capacity

Clamp bases are seated on slide plates allowing movement with reduced friction – this means the pipe systems can move without constraint during thermal expansion.



Weld-on slide plates



Type 28 with embedded slide plates



Type 29 with load plate and PTFE slide plates



Typical use of slide plates under clamp bases

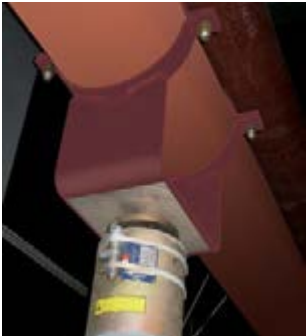

Other fields of application for LISEGA slide plates are uses where heavy loads must be moved horizontally. By using slide plates the force required for movement can be reduced by as much as 60%. The use of slide plates has a favorable effect on the whole pipe system layout.

Build of the slide plates

LISEGA slide plates for the temperature range up to 180°C are made of the low-friction material PTFE. For temperatures from 180°C up to 350°C a special high-temperature material is used that not only increases heat resistance but also optimizes the mechanical properties.

The LISEGA slide plate consists basically of a supporting plate of carbon steel with a weldable primer coating in which the low-friction material is embedded.

Optionally the supporting plate can be supplied hot dip galvanized.

The counterface is a stainless steel plate. Optionally **the stainless steel plate, that must be ordered separately**, can be welded to carbon steel support plate or it is attached to the bottom of the clamp base in the factory and can be used immediately.

Use of slide plates for pipe guides type 49 -G..

Specially developed for vertical installation, such as for example for type 49 -G.. pipe guides, the slide plate is bolted to the support plate.

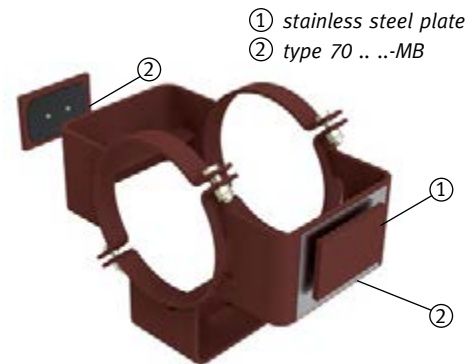

slide bearing / guide through clamp base type 49 G3-SP with slide plates

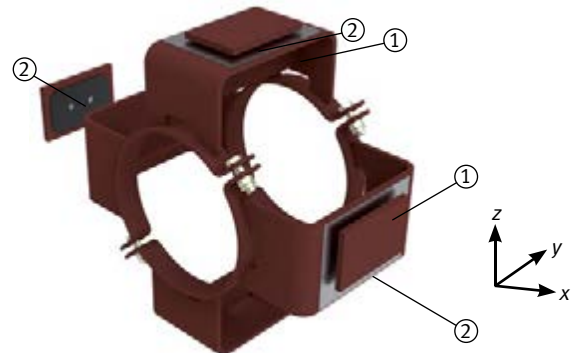

X-Z-stop with guide in Y direction through clamp base Type 49 G4-SP with slide plates

Friction values μ in dependence on operating temperature

slide plates	max. operating temp.	150°C	180°C	280°C	300°C	350°C
standard PTFE low-friction material		$\mu \leq 0.1$				
high temperature low-friction material		$0.1 \leq \mu \leq 0.18$			$\mu \leq 0.25$	

Information on construction and assembly of slide plates

- Parallel installation of the slide plates and counterfaces is required.
- In every possible bearing position the slide plates must be fully covered by the counterfaces.
- The components are to be fitted so that any bending of the slide plates or counterfaces is prevented.

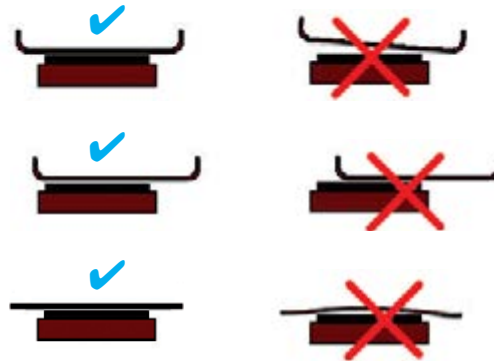

Installation of slide plates

- Type 70 .. 1. Is tack-welded with single datum points. If all-round welding is required, the temperature of the PTFE material must not hereby exceed 260°C. When welding, the PTFE material or the restraining surfaces of the support plate must be protected from dirt.
- It is recommended to install the slide plates only horizontally. For vertical installation type 70 .. -MB is to be used. When it has been ensured that the counterface is always in contact with the PTFE, the standard component shape 70 can also be used.
- Type 70 .. 2. And type 70 .. 3. Are bolted to the steelwork with M10 or M12 cylinder bolts. These bolts do not form part of the scope of supply. Special sizes can be supplied on request.

Special sizes can be supplied on request.



Clamp base type 49 on slide plate with clamp connection to steelwork



Clamp base type 49 and spring support type 28 with slide plates

load% nom. load type	travel range 1				travel range 2				travel range 3			
	40%	60%	80%	100%	40%	60%	80%	100%	40%	60%	80%	100%
29 C. 19												
29 D. 19												
29 1. 18												
29 2. 18												
29 3. 18												
29 4. 18												
29 5. 18												
29 6. 18												
29 7. 18												
29 8. 18												
29 9. 18												

Recommended use of PTFE slide plates for spring supports type 29 .. 1.

Slide plates to weld-on Type 70

Slide plates to weld-on (rectangular shape) type 70 11 11 to 70 48 11

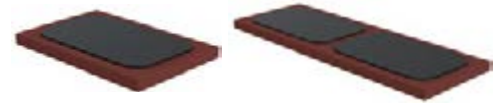
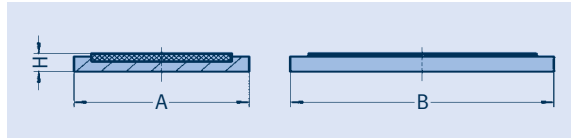

① The 6th place is to be filled out in dependence of the operating temperature.

② For friction values of slide plates: see table on p. 7.11.

type ①	max. load [kN]			A	B	H	sliding surface	weight [kg]
	150°C 1	180°C	350°C ②					
70 11 1.	13	7	25	50	50	10	∅ 40	0.2
70 12 1.	22	13	40	50	100	10	30 x 80	0.3
70 13 1.	37	22	70	50	150	10	30 x 130	0.4
70 14 1.	52	31	100	50	200	10	30 x 180	0.6
70 16 1.	82	49	160	50	300	10	30 x 280	0.8
70 17 1.	105	62	205	50	390	10	2 x 30 x 180	1.0
70 18 1.	135	80	265	50	490	10	2 x 30 x 230	1.3
70 22 1.	59	36	120	100	100	12	80 x 80	0.7
70 23 1.	98	60	200	100	150	12	80 x 130	1.0
70 24 1.	138	84	280	100	200	12	80 x 180	1.3
70 26 1.	219	132	440	100	300	12	80 x 280	1.9
70 27 1.	280	168	560	100	390	12	2 x 80 x 180	2.5
70 28 1.	360	216	720	100	490	12	2 x 80 x 230	3.1
70 33 1.	163	99	330	150	150	12	130 x 130	1.4
70 34 1.	228	138	460	150	200	12	130 x 180	1.9
70 36 1.	358	216	720	150	300	12	130 x 280	2.7
70 37 1.	465	276	920	150	390	12	2 x 130 x 180	3.6
70 38 1.	595	354	1180	150	490	12	2 x 130 x 230	4.4
70 44 1.	318	192	640	200	200	12	180 x 180	2.4
70 46 1.	498	300	1000	200	300	12	180 x 280	3.6
70 47 1.	645	384	1280	200	390	12	2 x 180 x 180	5.4
70 48 1.	825	492	1640	200	490	12	2 x 180 x 230	6.8

Order details:
slide plate to weld-on
type 70 .. 1.

Slide plate to weld-on (round shape) type 70 05 1. to 70 20 1.

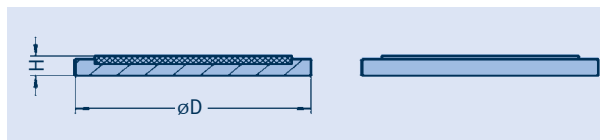

① The 6th place is to be filled out in dependence of the operating temperature.

② For friction values of slide plates: see table on p. 7.11.

type ①	max. load [kN]			∅D	H	sliding surface	weight [kg]
	150°C 2	180°C	350°C ②				
70 05 1.	13	7	25	50	10	∅ 40	0.1
70 08 1.	33	19	65	85	12	∅ 65	0.4
70 10 1.	50	30	100	100	12	∅ 80	0.5
70 13 1.	90	57	190	130	12	∅ 110	0.9
70 17 1.	175	106	350	170	12	∅ 150	1.4
70 20 1.	254	152	505	200	12	∅ 180	1.9

Order details:
slide plate to weld-on
type 70 .. 1.

Slide plates for bolting Type 70

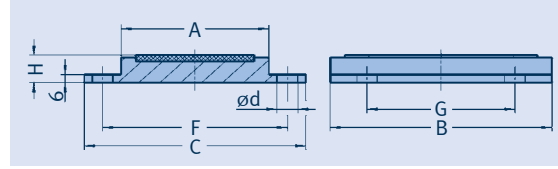
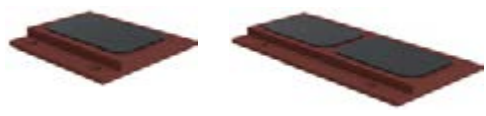

**Slide plates for bolting
(rectangular shape
lengthwise)
type 70 11 2. to 70 48 2.**

type ①	max. load [kN]			A	B	H	sliding surface	C	F	G	bore holes	$\varnothing d$	weight [kg]
	150°C	180°C	350°C ②										
70 11 2.	13	7	25	50	50	22	$\varnothing 40$	100	75	0	2	12	0.5
70 12 2.	22	13	40	50	100	22	30 x 80	100	75	60	4	12	1.0
70 13 2.	37	22	70	50	150	22	30 x 130	100	75	100	4	12	1.5
70 14 2.	52	31	100	50	200	22	30 x 180	100	75	150	4	12	2.0
70 16 2.	82	49	160	50	300	22	30 x 280	100	75	250	4	12	2.9
70 17 2.	105	62	205	50	390	22	2 x 30 x 180	100	75	300	4	12	3.8
70 18 2.	135	80	265	50	490	22	2 x 30 x 230	100	75	350	4	12	4.7
70 22 2.	59	36	120	100	100	22	80 x 80	150	125	60	4	14	1.7
70 23 2.	98	60	200	100	150	22	80 x 130	150	125	100	4	14	2.5
70 24 2.	138	84	280	100	200	22	80 x 180	150	125	150	4	14	3.3
70 26 2.	219	132	440	100	300	22	80 x 280	150	125	250	4	14	5.0
70 27 2.	280	168	560	100	390	22	2 x 80 x 180	150	125	300	4	14	6.4
70 28 2.	360	216	720	100	490	22	2 x 80 x 230	150	125	350	4	14	8.1
70 33 2.	163	99	330	150	150	22	130 x 130	200	175	100	4	14	3.6
70 34 2.	228	138	460	150	200	22	130 x 180	200	175	150	4	14	4.7
70 36 2.	358	216	720	150	300	22	130 x 280	200	175	250	4	14	7.0
70 37 2.	465	276	920	150	390	22	2 x 130 x 180	200	175	300	4	14	9.1
70 38 2.	595	354	1180	150	490	22	2 x 130 x 230	200	175	350	4	14	11.4
70 44 2.	318	192	640	200	200	22	180 x 180	250	225	150	4	14	6.1
70 46 2.	498	300	1000	200	300	22	180 x 280	250	225	250	4	14	9.0
70 47 2.	645	384	1280	200	390	22	2 x 180 x 180	250	225	300	4	14	11.7
70 48 2.	825	492	1640	200	490	22	2 x 180 x 230	250	225	350	4	14	14.7

- ① The 6th place is to be filled out in dependence of the operating temperature.
- ② For friction values of slide plates: see table on p. 7.11.

Order details:
slide plate for bolting
type 70 .. 2.

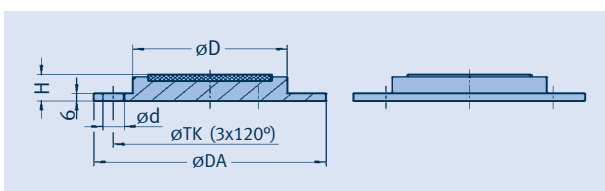

**Slide plates for bolting
(round shape)
type 70 05 2. to 70 20 2.**

type ①	max. load [kN]			$\varnothing D$	$\varnothing DA$	H	sliding surface	$\varnothing TK$	$\varnothing d$	weight [kg]
	150°C	180°C	350°C ②							
70 05 2.	13	7	25	50	90	22	$\varnothing 40$	70	12	0.5
70 08 2.	33	19	65	85	125	22	$\varnothing 65$	105	12	1.2
70 10 2.	50	30	100	100	150	22	$\varnothing 80$	125	14	1.6
70 13 2.	90	57	190	130	180	22	$\varnothing 110$	155	14	2.5
70 17 2.	175	106	350	170	220	22	$\varnothing 150$	195	14	3.9
70 20 2.	254	152	505	200	260	22	$\varnothing 180$	230	18	5.4

- ① The 6th place is to be filled out in dependence of the operating temperature.
- ② For friction values of slide plates: see table on p. 7.11.

Order details:
slide plate for bolting
type 70 .. 2.

Slide plates for bolting Type 70

Slide plates for bolting
(transverse rectangular shape)
type 70 12 3. to 70 48 3.

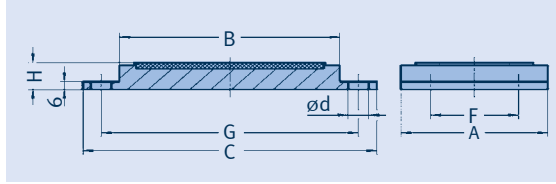

① The 6th place is to be filled out in dependence of the operating temperature.

② For friction values of slide plates: see table on p. 7.11.

type ①	max. load [kN]			A	B	H	sliding surface	C	F	G	bore holes	ød	weight [kg]
	150°C	180°C	350°C ②										
70 12 3.	22	13	40	50	100	22	30 x 80	150	0	125	2	12	0.9
70 13 3.	37	22	70	50	150	22	30 x 130	200	0	175	2	12	1.3
70 14 3.	52	31	100	50	200	22	30 x 180	250	0	225	2	12	1.6
70 16 3.	82	49	160	50	300	22	30 x 280	350	0	325	2	12	2.3
70 17 3.	105	62	205	50	390	22	2 x 30 x 180	440	0	415	2	12	3.0
70 18 3.	135	80	265	50	490	22	2 x 30 x 230	540	0	515	2	12	3.7
70 23 3.	98	60	200	100	150	22	80 x 130	200	60	175	4	14	2.4
70 24 3.	138	84	280	100	200	22	80 x 180	250	60	225	4	14	3.1
70 26 3.	219	132	440	100	300	22	80 x 280	350	60	325	4	14	4.5
70 27 3.	280	168	560	100	390	22	2 x 80 x 180	440	60	415	4	14	5.8
70 28 3.	360	216	720	100	490	22	2 x 80 x 230	540	60	515	4	14	7.1
70 34 3.	228	138	460	150	200	22	130 x 180	250	100	225	4	14	4.6
70 36 3.	358	216	720	150	300	22	130 x 280	350	100	325	4	14	6.6
70 37 3.	465	276	920	150	390	22	2 x 130 x 180	440	100	415	4	14	8.5
70 38 3.	595	354	1180	150	490	22	2 x 130 x 230	540	100	515	4	14	10.6
70 46 3.	498	300	1000	200	300	22	180 x 280	350	150	325	4	14	8.8
70 47 3.	645	384	1280	200	390	22	2 x 180 x 180	440	150	415	4	14	11.3
70 48 3.	825	492	1640	200	490	22	2 x 180 x 230	540	150	515	4	14	14.0

Order details:
slide plate for bolting
type 70 .. 3.



Slide plate type 70 .. -MB for
vertical or overhead installation

Supplementary order details:
slide plate 70 .. -MB